

GOODWE PARALLEL CONNECTION SOLUTION

VER: 03, UPDATED ON JANUARY 16TH, 2012

WHY PARALLEL CONNECTION IS REQUIRED IN STORAGE SYSTEM?

In many countries and areas, photovoltaic storage system has become a preferred energy choice due to the high costs of electricity and government’s supportive policies. In addition to the pursuit of cheaper energy, mature and innovative technologies in solar field also contribute to photovoltaic storage solution with UPS features and larger capacity.

In residential scenario, a single storage system with only one hybrid inverter deployed is quite common and its capacity is usually not large.

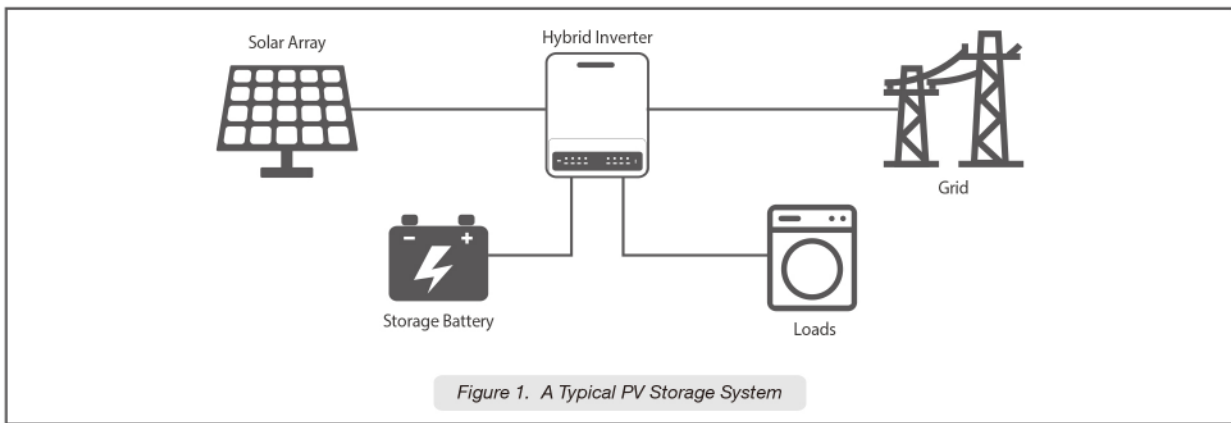

Figure 1. A Typical PV Storage System

When it comes to commercial scenario with larger capacity demand, a single storage system may require an upgrade. Parallel connection of multiple hybrid inverters in a storage system is an optimum option to realize this capacity expansion.

WHAT IS GOODWE PARALLEL CONNECTION SOLUTION?

This article focuses on the parallel connection of GoodWe three-phase hybrid inverter ET series.

● **WHAT ADDITIONAL DEVICE IS NEEDED IN THIS SOLUTION?**

In parallel system, SEC1000 is needed and applied for multi-CPU coordination and energy management at system level.

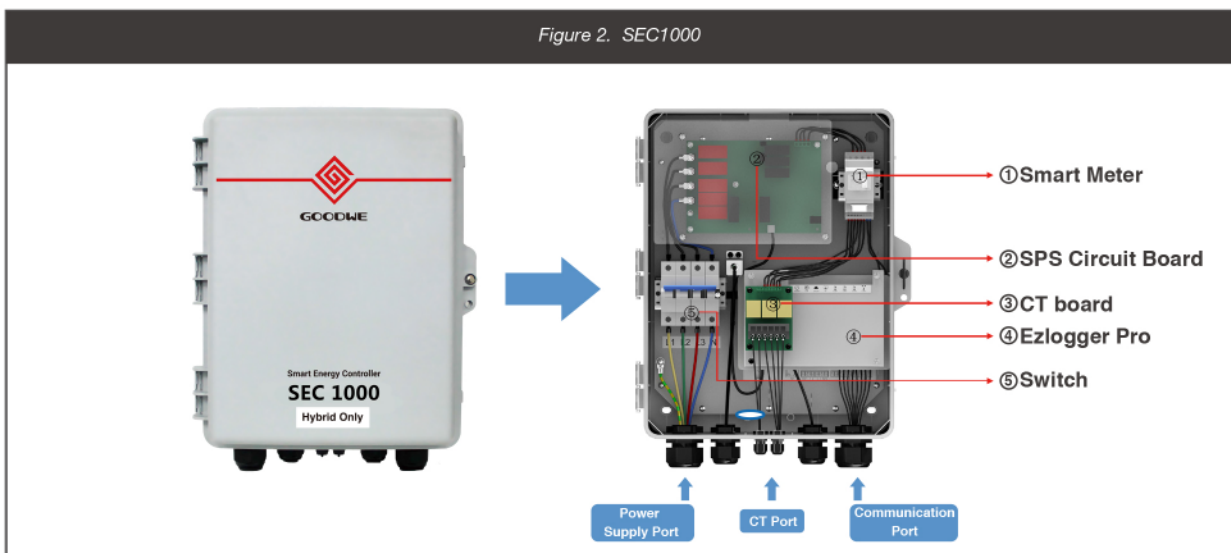

Figure 2. SEC1000

GOODWE PARALLEL CONNECTION SOLUTION

VER: 03, UPDATED ON JANUARY 16TH, 2020

Here inside SEC1000 integrated are functions of Ezlogger Pro and Smart Meter. With the participation of SEC1000 in this parallel system, real-time information exchange and interaction with utility grid is realized and energy flow in the system is under proper control.

NOTE:

1. Standard SEC1000 cannot be applied in ET parallel system and Hybrid Only version of SEC1000 is designed for ET parallel connection application.
2. There is a label on the front cover of SEC1000 box saying “Hybrid Only” to differentiate it from standard SEC1000. In addition, the serial number of SEC1000 (Hybrid Only) begins with 99 while that of standard SEC1000 with 91.
3. Please install Wi-Fi module to each ET inverter in the system for monitoring purpose as SEC1000 (Hybrid Only) is just for energy management.
4. There is special requirement on the firmware version of devices in paralleling system, ET with DSP version 01 or newer and ARM version 09 or newer, and SEC1000 (Hybrid Only) with firmware version 01.

● HOW TO DO CONNECTION?

Scenario 1: No more than three ETs in a parallel system

When there are two or three ETs connected to grid in parallel, it is in the same way to connect PV strings, batteries and loads to ETs in the parallel system as in a single storage system. However, for communication and management purpose, each ET should be connected to ports of SEC1000 through standard RJ45 cable. Moreover, there is no need to connect Smart Meter for each ET because there is one already integrated in SEC1000, which takes the role of measurement for whole system.

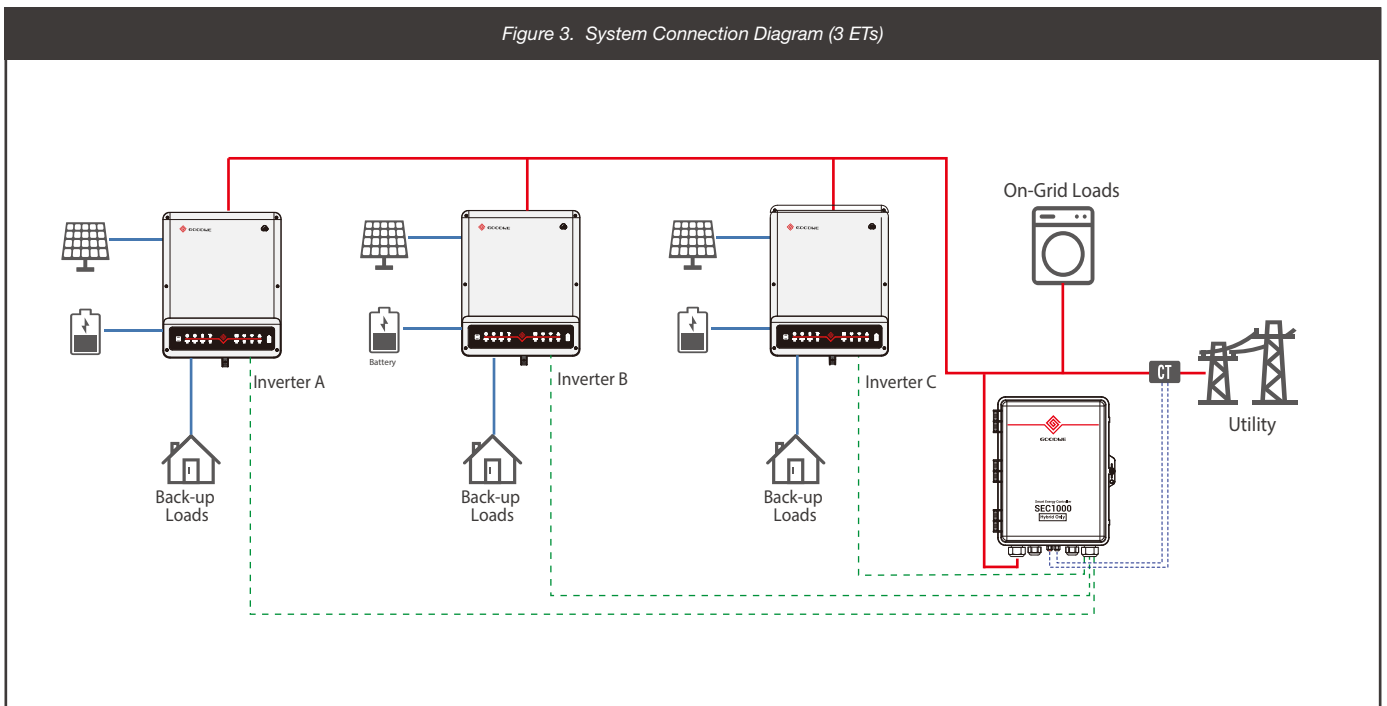

Scenario 2: No more than ten but more than three ETs in parallel system

When there are more than three ETs in the parallel system, there is no much difference in connection with that of a parallel system with no more than three ETs. However, the communication port of SEC1000 may communicate with more than one ETs where the last one (Inverter A, B or C) in the string should be connected to the port (COMM1, 2, or 3).

GOODWE PARALLEL CONNECTION SOLUTION

VER: 03, UPDATED ON JANUARY 16TH, 2020

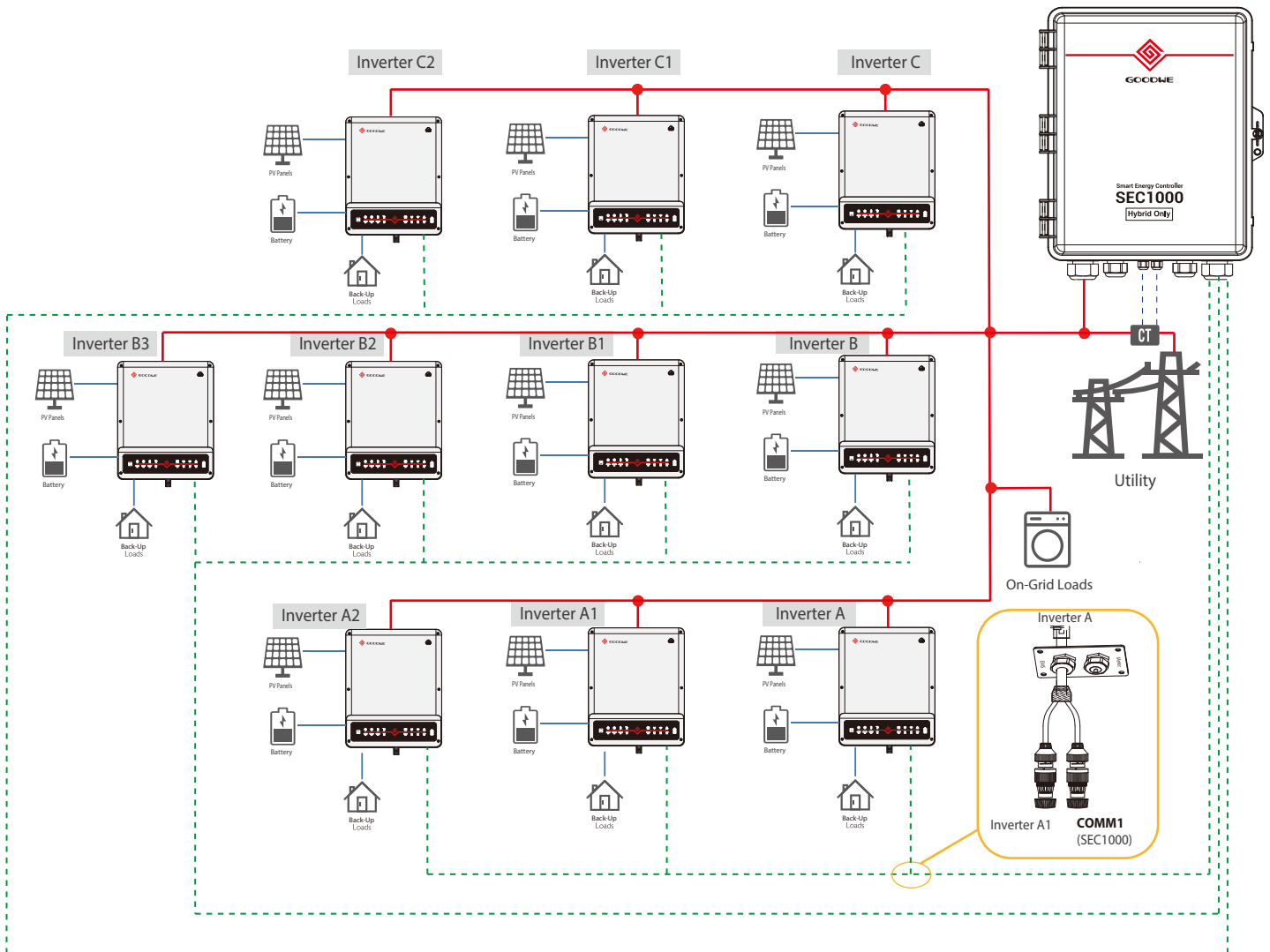

Figure 4. System Connection Diagram (10 ETs)

Splitter (as shown in Figure 4.) is required to replace the original Meter & EMS cover attached on the inverter for connection with SEC1000. The number of ETs connected to the three communication ports should be even, for example, two ETs communicate to COMM1, COMM2 and COMM3 respectively in a parallel system with total six ETs deployed.

Name	SEC1000	
Communication Port (RS485)	COMM1	Interface to Inverter A in a string
	COMM2	Interface to Inverter B in a string
	COMM3	Interface to Inverter C in a string
	COMM4	Interface to Meter
Max. Distance from Inverter	1000M	
Max. Number of Inverter connected	10 PCS*	
Other Functions	Anti-reverse function; Reactive compensation	

*At this moment, it supports up to 10 ETs in the same parallel system.

GOODWE PARALLEL CONNECTION SOLUTION

VER: 03, UPDATED ON JANUARY 16TH, 2020

The communication ports inside SEC1000 is compatible with 2-pin RS485 connector and at least four lines of standard RJ45 cable should be injected into the connector.

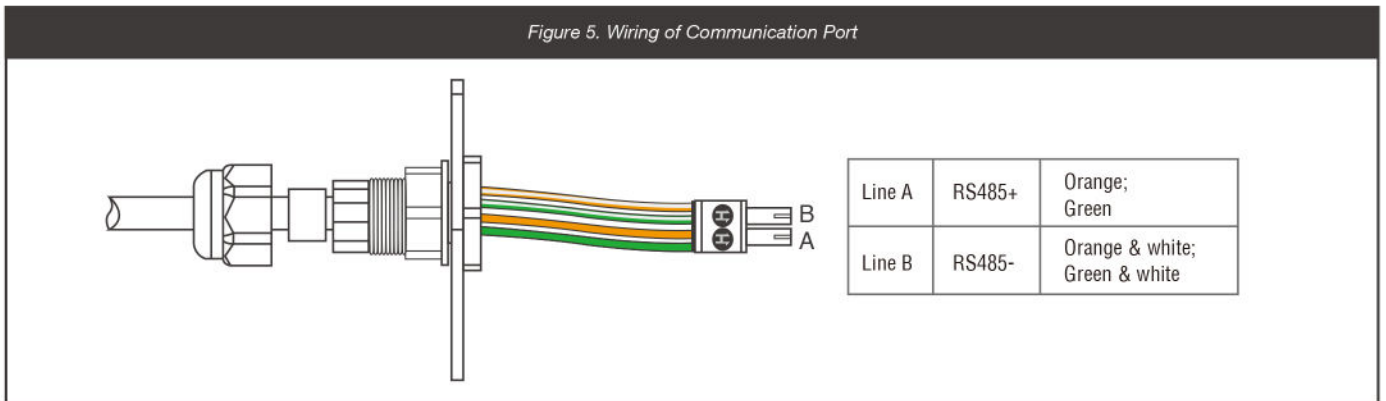

Even though splitter may be used to connect all of the three ETs into one string when it is unavailable to accommodate one communication port with just one ET, it's recommended to do so for optimum communication and control performance.

- NOTE:**
1. Please inform your sales representative if you want to apply parallel connection in your solar storage system because special components will be required.
 2. No separate Smart Meter should be connected to any ET in the system because Smart Meter is already integrated in SEC1000.
 3. User can select appropriate CTs according to system capacity or total load consumption. The rated secondary current should be 5A.
 4. There are 5 splitters which come along with SEC1000 (for hybrid only).

● HOW TO DO CONFIGURATION?

With all installation and connection steps done, there are still two steps to set the whole system up, namely system configuration on Promate and PV Master.

On the “Ezlogger Pro” setting page of Promate, you should enter the values of actual system capacity and CT ratio. In addition, you should enter the amount of ET connected on each COMM port.

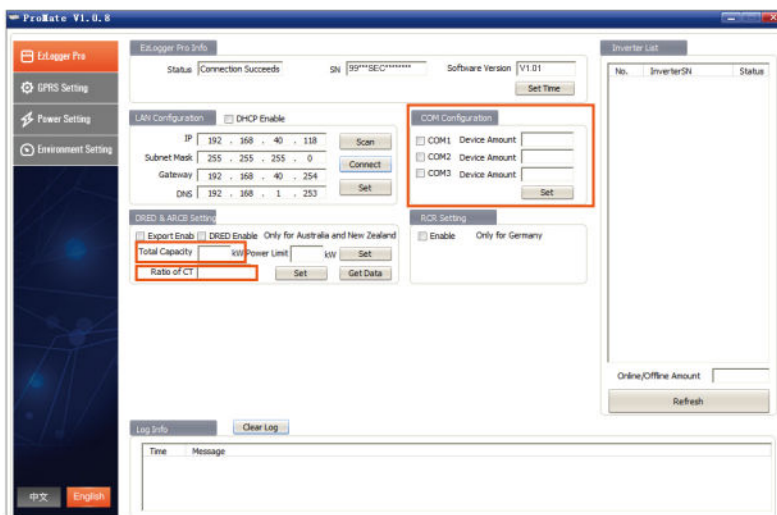

Figure 6. Configuration Page of Ezlogger Pro

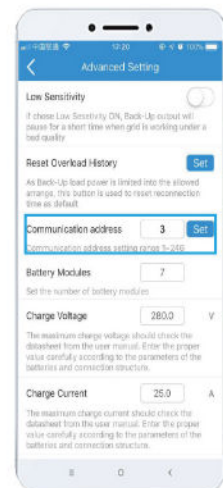

Figure 7. Configuration Page of PV Master

GOODWE PARALLEL CONNECTION SOLUTION

VER: 03, UPDATED ON JANUARY 16TH, 2020

Then you should go to the “Advanced Setting” page of PV Master and set communication address for ETs in the system one by one. Each ET should be assigned with a different address and the range for a parallel system is recommended to be no wider than 10. For example, you may set the communication addresses of the six ETs in a parallel system as 1, 2, 3, 4, 5, and 6.

NOTE:

1. You may refer to *Instruction on ET Paralleling System Composition* about setting of other functions.
2. You may refer to *ET User Manual* for Wi-Fi configuration and installation instruction.

● **HOW DOES THE PARALLEL SYSTEM WORK?**

The basic operation mode of parallel system is same with that of a single storage system with PV energy to support the loads first, then to charge battery and excess energy to feed into grid if anti-reverse function is disabled.

With additional device SEC1000, energy generated in this system is shared to support loads together. In other words, loads with larger on on-grid side can be supported by solar energy drawn from multiple ETs or batteries in the system. Moreover, loads on back-up side of ET will be supported by other batteries in the system when there is no enough energy in the battery connected to the same ET.

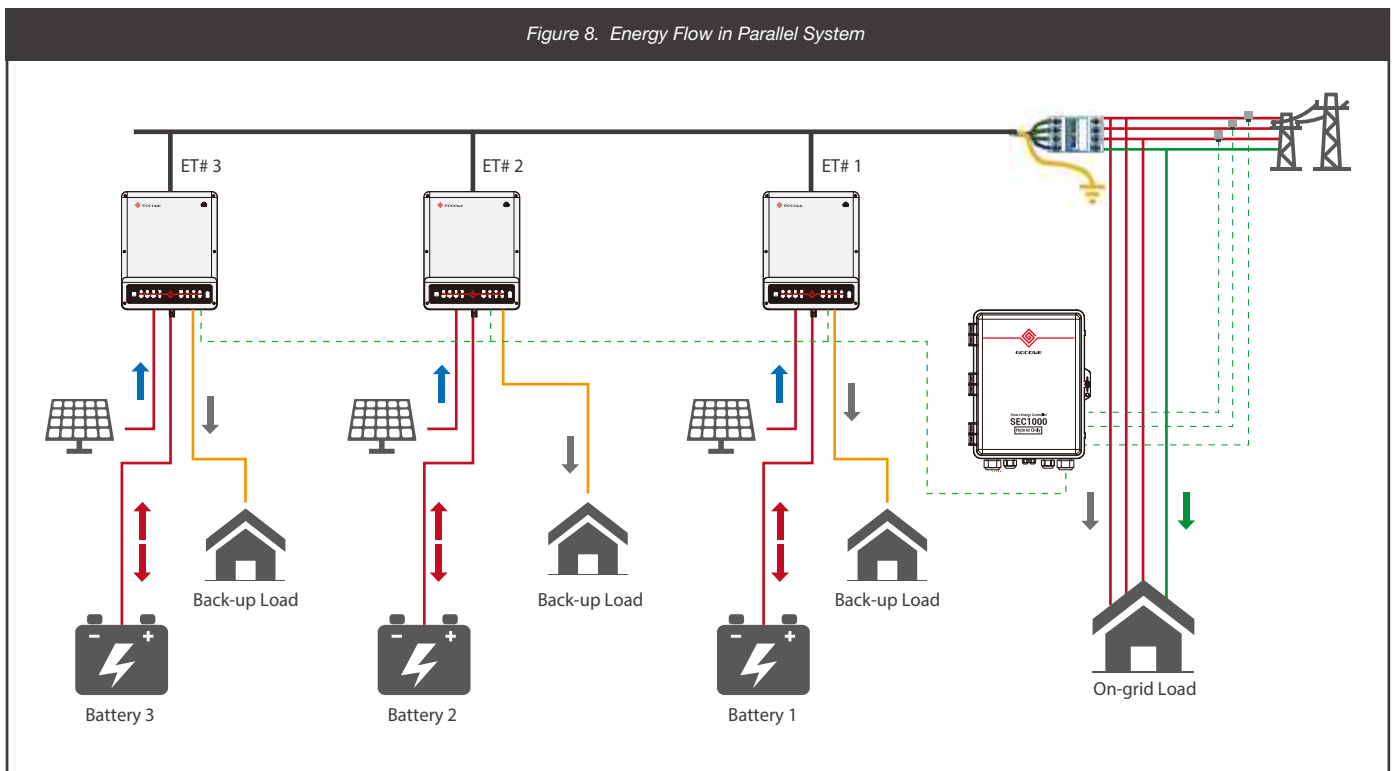

Theoretically speaking, batteries in this system can reach fully-charged status almost simultaneously since energy is shared within the system and discharge at different power to support loads based on the real-time usable energy in each battery simultaneously.

GOODWE PARALLEL CONNECTION SOLUTION

VER: 03, UPDATED ON JANUARY 16TH, 2020

● **HOW TO MONITOR THE PARALLEL SYSTEM?**

Through Wi-Fi, data from inverter, battery, Smart Meter and load are transmitted to GoodWe server and they are accessible to customer through GoodWe monitoring platform SEMS Portal (both webpage and app). From the plant info page, you are able to check the following info:

- **PV (W):** PV generation power in real time. It displays total PV power in this system.
- **SOC (%):** Energy balance of battery. It displays the mean SOC value in percentage of all batteries in the parallel system.
- **Battery (W):** Real-time battery state of charge or discharge.
- **Meter (W):** Energy flow to or from grid. It tells that this system is in what power buying electricity from grid or in what power feeding excess electricity to grid.
- **Load (W):** Load consumption in real time of all devices within this system.

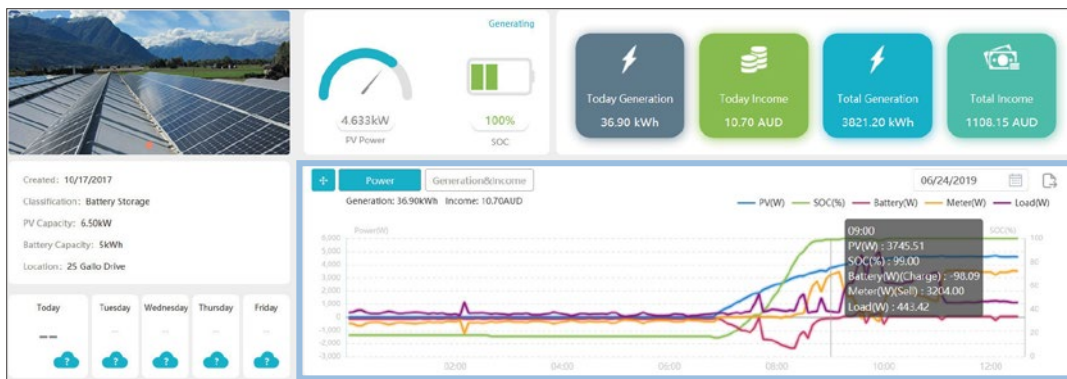

Figure 9. Plant Info Page on SEMS Portal

From the device info page, you are able to check real-time data such as power, PV input (voltage & current), daily output etc. of each device. All ETs in parallel connection should be registered under the same power plant on SEMS Portal.



Figure 10. Device Info Page on SEMS Portal

*The SOC value on plant info page may differ from that on device info page.

Notice
 The information in this document is subject to change without notice, all information in this document do not constitute any kind of warranty. Please check with GoodWe Solar Academy 'academy@goodwe.com' for the latest version.

Welcome to check out instruction videos from GoodWe Solar Academy at:
YOUTUBE & FACEBOOK: GOODWE SOLAR ACADEMY