



Balcony Solar Mounting Bracket



Balcony solar mounting bracket is a pre-assembled mounting structure for solar modules installations to balconies. It can affix to most common size balconies.

Main Benefits

The material of bracket is aluminum and 304 stainless steel, which makes it suitable for even the toughest of environments, such as corrosive sites close to the coast.

The components are suitable for 60 cell, 66 cell and 72cell panels. The mounting bracket can cover most commonly size balconies. And it is compatible with metal railings.

Technical Details

Module Orientation	Landscape
Module Type	Framed
Tilt Angle	90 degree (parallel to railing)
Material	AL6005-T5+ SUS 304
Weight	7.8kg
Size	1033x133x130mm

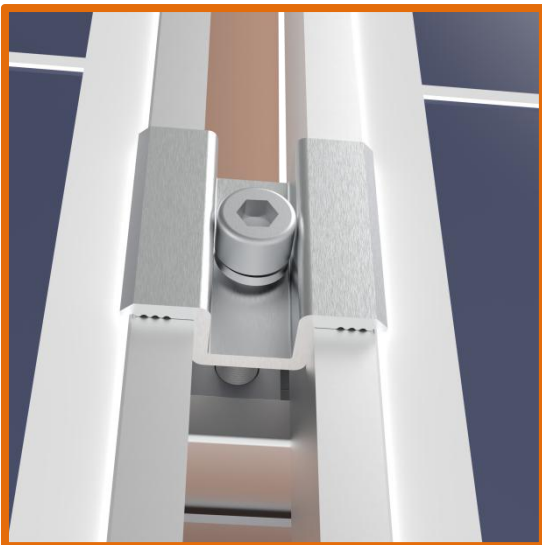
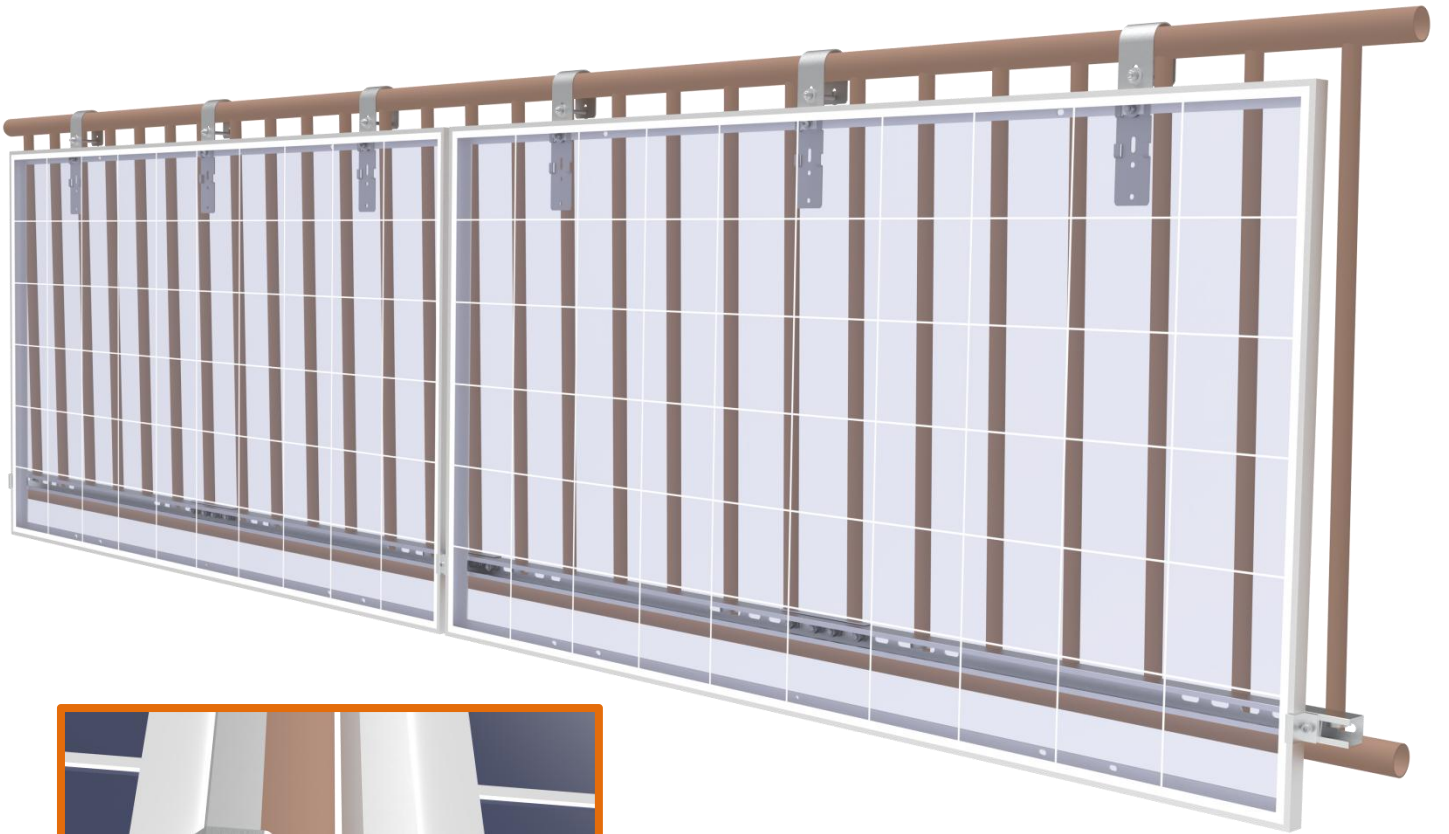
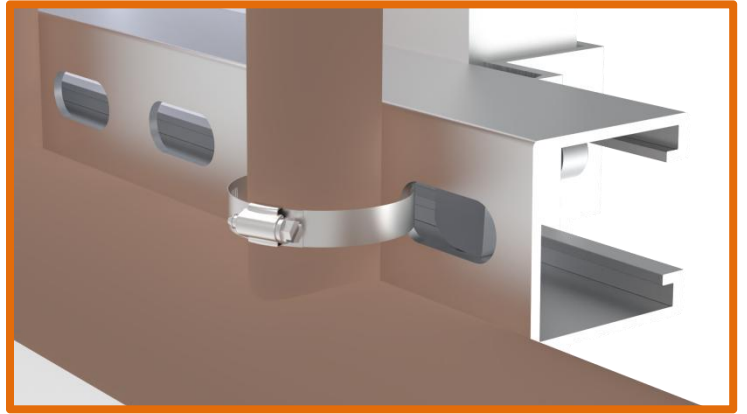



J hook x6

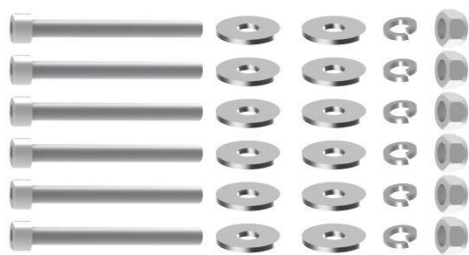

M8x80mm x6



End Clamp x2

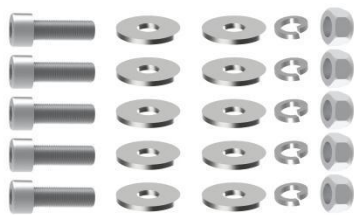

M8x25mm x5



M6x25mm x2



Inter Clamp x1



C Rail x4



connector x3



hoop x8